

SHELL & TUBE HEAT EXCHANGER







KASERA Heat Transfer Pvt. Ltd. was established in 1955. The high quality Manufacture of Shell & Tube Heat Exchanger products. In addition, services, repairs, re-tubing, finning, Tube sheet drilling & upgrading now has been added to the product Portfolio at the Bhilwara site.

With more than 57 years experience in the design and fabrication of all major process Cooling components, including tubing, headers, plenum chambers, shell body & Structure, we are able to offer customers an unparalleled guarantee. On the thermal and mechanical performance of our equipment.

It is always our ambition to exceed our customers expectations.

SOFTWARE DESIGNING & FACILITIES

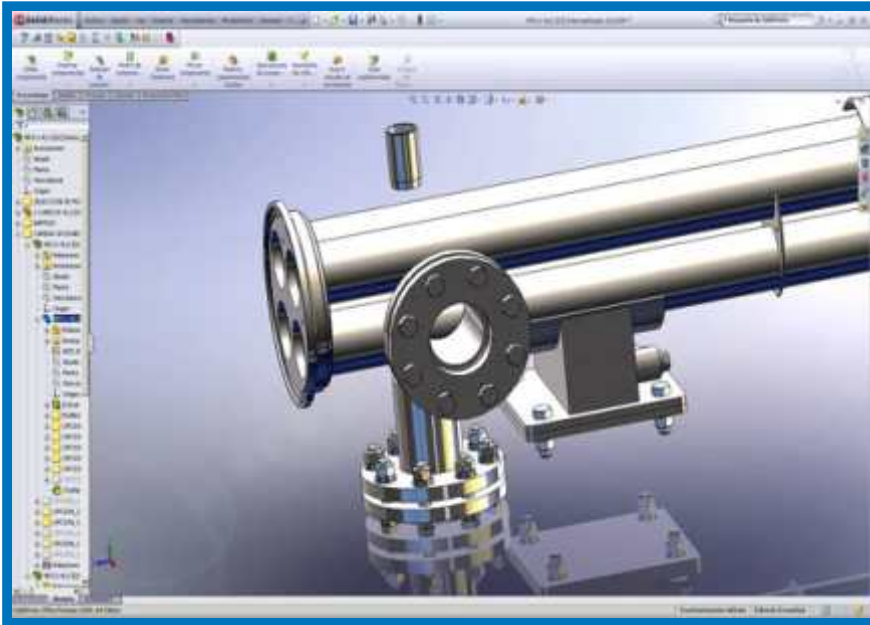

KASERA Heat Transfer Pvt. Ltd. a number of software Programs to determine. The best heat exchanger Type, model and size for your particular Application. Our Representative has all the details.

Heat Exchanger specification

GENERAL: Heat exchanger shall be of shell and tube design, of carbon steel construction, including shell, tube sheets, and baffles, providing single, two and Four pass configurations as determined by thermal requirements.

MOUNTING: Heat exchanger supports shall be bolted to the unit, and provide elongated mounting holes to compensate for thermal expansion.

SELECTING THE RIGHT HEAT EXCHANGER

Our representative has complete information on heat exchanger products to help you meet your particular application requirements. What's more, we can use advanced computer software programs to quickly and easily determine the most efficient heat exchanger to match your specific parameters. We utilize the most current, up to date software for thermal, hydraulic and mechanical design and evaluation of units. The process of heat Exchanger design and performance calculations is condensed into one simple, dependable program that we can use to solve virtually any heat transfer problem. Give us a call.

Our advanced thermal research lab is one of the largest and best equipped testing facilities in the industry. Staffed by a team of experienced chemical, mechanical and metallurgical engineers, it is used to solve problems and identify opportunities for product improvement and development. It is also available to our customers to test products and systems under actual operating conditions, assuring reliability prior to field deployment.



DESIGNING HEAT EXCHANGER

KASERA makes use of leading-HP computer equipment, including the latest Computer Aided Design systems, to ensure maximum efficiency in:

- Thermal design
- Mechanical design of headers and steel structure
- Noise level predictions
- Preparation of the specification sheet
- Preparation of the general outline drawings
- Preparation of proposals
- Price estimation

Typical Components of an Shell & Tube Heat Exchanger

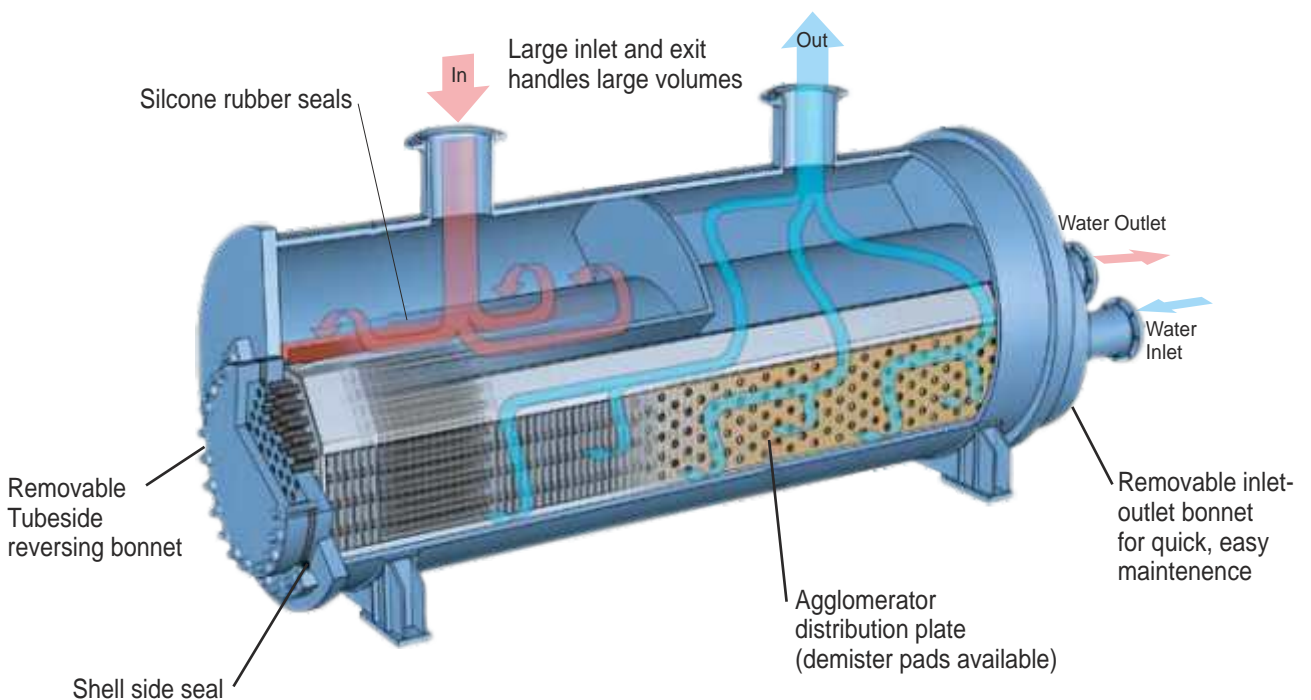
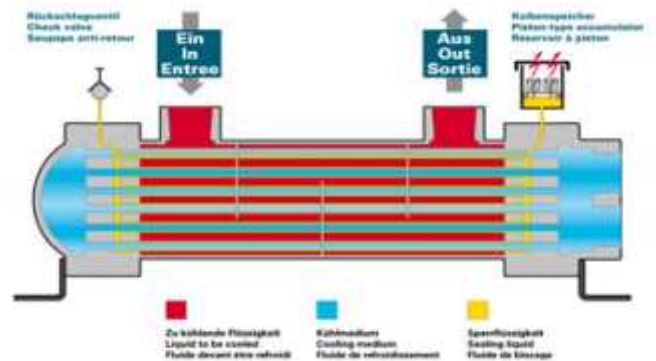

CHOOSING THE U-TUBE DESIGN

3"–8" Diameter Commercial Standard Models

Standard Materials of Construction

Shell: Steel Pipe or Tubing
Tubes: Copper, Admiralty or 90/10 CuNi
Tubesheets: Steel, Stainless Steel or 90/10 CuNi
Bonnet: Cast Iron
Baffles: Carbon Steel
Gaskets: Compressed Fiber

3"–8" Diameter Stainless Steel Models

Standard Materials of Construction

Shell: Welded 304 Stainless
Tubes: 304 Stainless Steel
Tubesheets: 304 Stainless Steel
Bonnet: Cast 304 Stainless
Baffles: 304 Stainless Steel
Gaskets: Compressed Fiber

5"–12" Diameter ASME and TEMA C Models

Standard Materials of Construction

Shell: Carbon Steel
Tubes: Copper, Admiralty, 90/10 CuNi, SS
Tubesheets: Carbon Steel, 90/10, Stainless Steel
Bonnet: Carbon Steel, Cast Ductile Iron
Baffles: Carbon Steel, SS
Gaskets: Compressed Fiber

Model shown is removable tubesheet U-tube with type 304 Stainless Steel tubing. Fixed bundle models also available.



3"–12" Diameter Models

Fixed or removable U-Tube bundles. HTR features non-ferrous construction while AHTR has all 316 stainless steel shell materials. Models available with ASME Code Stamp. AHTR models in 10" and 12" shell diameters have fabricated heads.

Standard Materials of Construction

Shell: 2"–3" Copper or SS; 4"–8" Red Brass or Stainless Steel
Tubes: Copper, Admiralty or Stainless Steel
Tubesheets: Forged Brass or Stainless Steel
Bonnet: Cast Iron, Bronzed or Stainless Steel
Baffles: Brass or SS
Bolting: Alloy Steel
Gaskets: Compressed Fiber
Brackets: Steel

Whitlock Type HTR Heat Exchangers shown is available from 3" thru 12" in diameter and up to 96" long in fixed or removable bundles.



CHOOSING THE PASS & NOZZLE

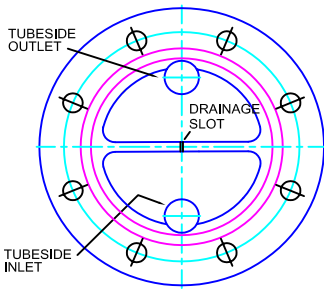

2-PASS DESIGN

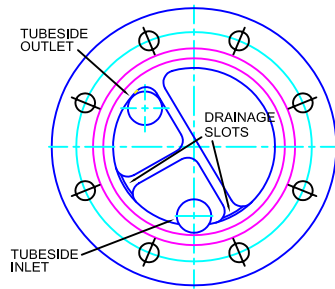

4-PASS DESIGN

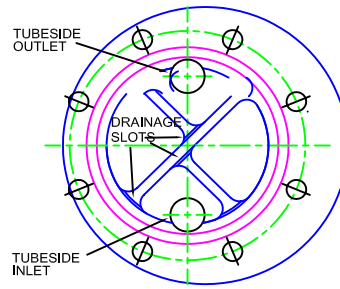

6-PASS DESIGN

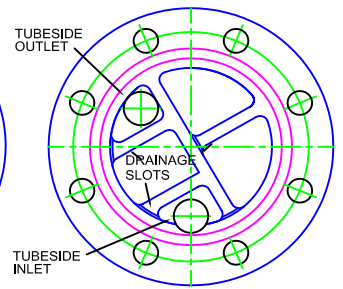

8-PASS DESIGN

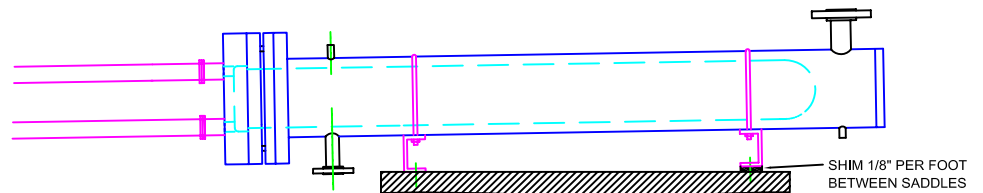
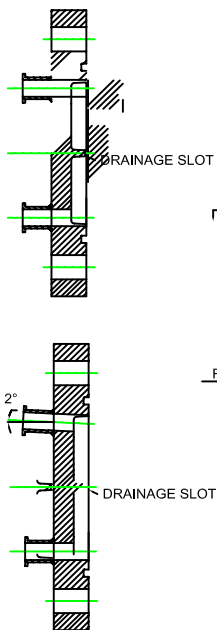

OPTION 1 (Head drains from top & bottom nozzle)

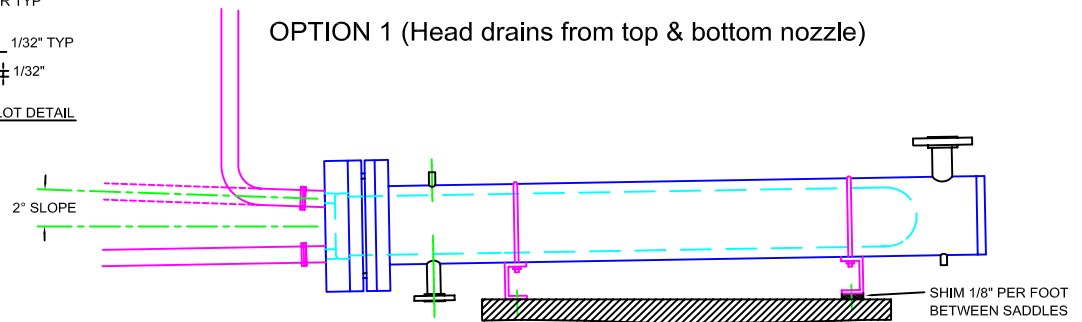





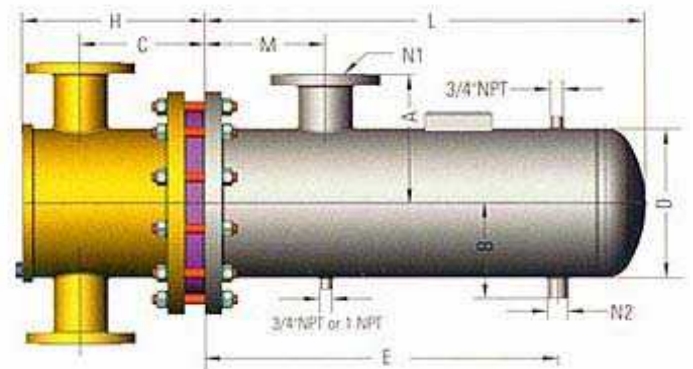
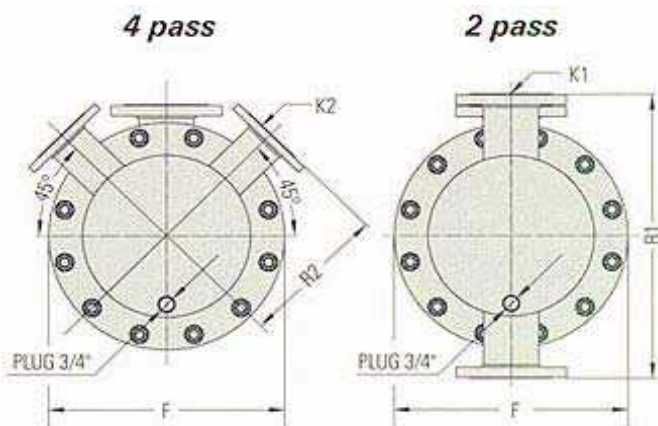



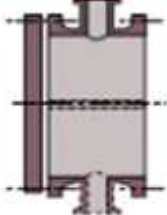

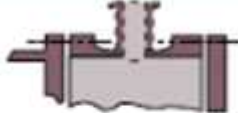
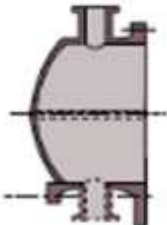
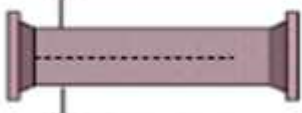
OPTION 2 (Head drains from bottom nozzle only)

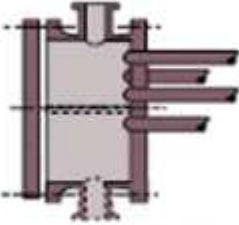
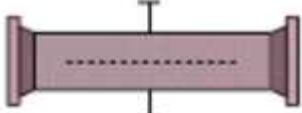
TUBESIDE IS FULLY DRAINABLE WHEN REAR U-BOLT SADDLE IS SHIMMED 1/8" PER FOOT. WHEN UNITS ARE SUPPLIED WITH WELDED SADDLES, THE SLOPE IS BUILT IN, NO SHIMMING IS REQUIRED.

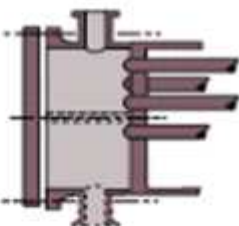
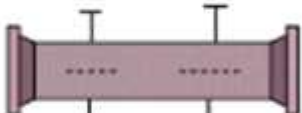
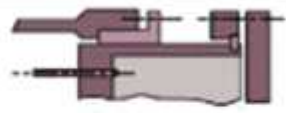
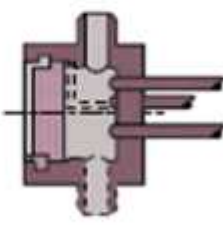
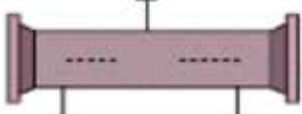
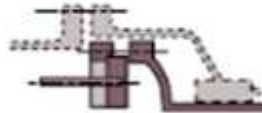

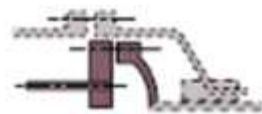
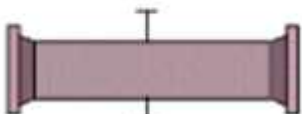
CHOOSING THE HEADER

| | Stationary Head Type | Shell Types | Rear Head Types | | |
|---|--|-------------|--|---|--|
| A |  <p>Removable Channel and Cover</p> | E |  <p>One-Pass Shell</p> | L |  <p>Fixed Tube Sheet Like 'A' Stationary Head</p> |
| B |  <p>Bonnet (integral Cover)</p> | F |  <p>Two-Pass Shell with Longitudinal Baffle</p> | M |  <p>Fixed Tube Sheet Like 'B' Stationary Head</p> |
| C |  <p>Integral With Tubesheet Removable Cover</p> | G |  <p>Split Flow</p> | N |  <p>Fixed Tube Sheet Like 'C' Stationary Head</p> |
| N |  <p>Channel Integral With Tubesheet and removable Cover</p> | H |  <p>Double Split Flow</p> | P |  <p>Outside Packed Floating Head</p> |
| D |  <p>Special High-Pressure Closures</p> | J |  <p>Divided Flow</p> | S |  <p>Floating Head with Backing Device</p> |
| | | K |  <p>Kettle-Type Reboiler</p> | T |  <p>Pull Through Floating Head</p> |
| | | X |  <p>Cross Flow</p> | U |  <p>U-Tube Bundle</p> |
| | | | | W |  <p>Externally Sealed Floating Tubesheet</p> |

OEM REQUIREMENT

Pre-engineered designs from stocked components

We can provide you with models with a non-ferrous shell circuit or all 316 stainless steel construction with a variety of options. Models with shell diameters from 2" through 120", in straight or U-tube designs, with 5mm to 100mm tube diameters are available. A variety of connections, hub orientations and materials of construction are available to meet virtually any OEM or industrial requirement.

These standard heat exchangers reflect the latest in heat transfer design technology. Assembled in state-of-the-art manufacturing facilities, they are available to meet most new installation, replacement or OEM requirements. Even "custom" units are assembled from standardized components and are quickly available at "standard" costs. Whatever your need, ARG will work with you to design and manufacture the right equipment quickly and cost effectively.

Depth in applications, designs and manufacturing

KASERA provides products for a broad range of duties.

| | | |
|--------------------|-------------------|---------------------|
| Compressor skids | Hydraulic systems | Molding machines |
| Stationary engines | Turbine skids | Marine applications |
| Refrigeration | Vapor service | S terilizing |

If your application falls outside these models, we can provide TEMA heat exchangers, plate technology, air cooled technology or refrigeration models. Models is available from stock or short lead times.



HTR U-tube designs are available in non-ferrous or stainless steel construction. Tubes can be seal welded or strength welded.



U-tube designs.

REFURBISHMENT/RE-TUBING

Many repairs – including the complete re-tubing of tube bundles, are offered. Our preference is to re-tube/refurbish in our own workshop where the work can be carried out under factory conditions. Where this is not possible on-site repairs can be arranged.

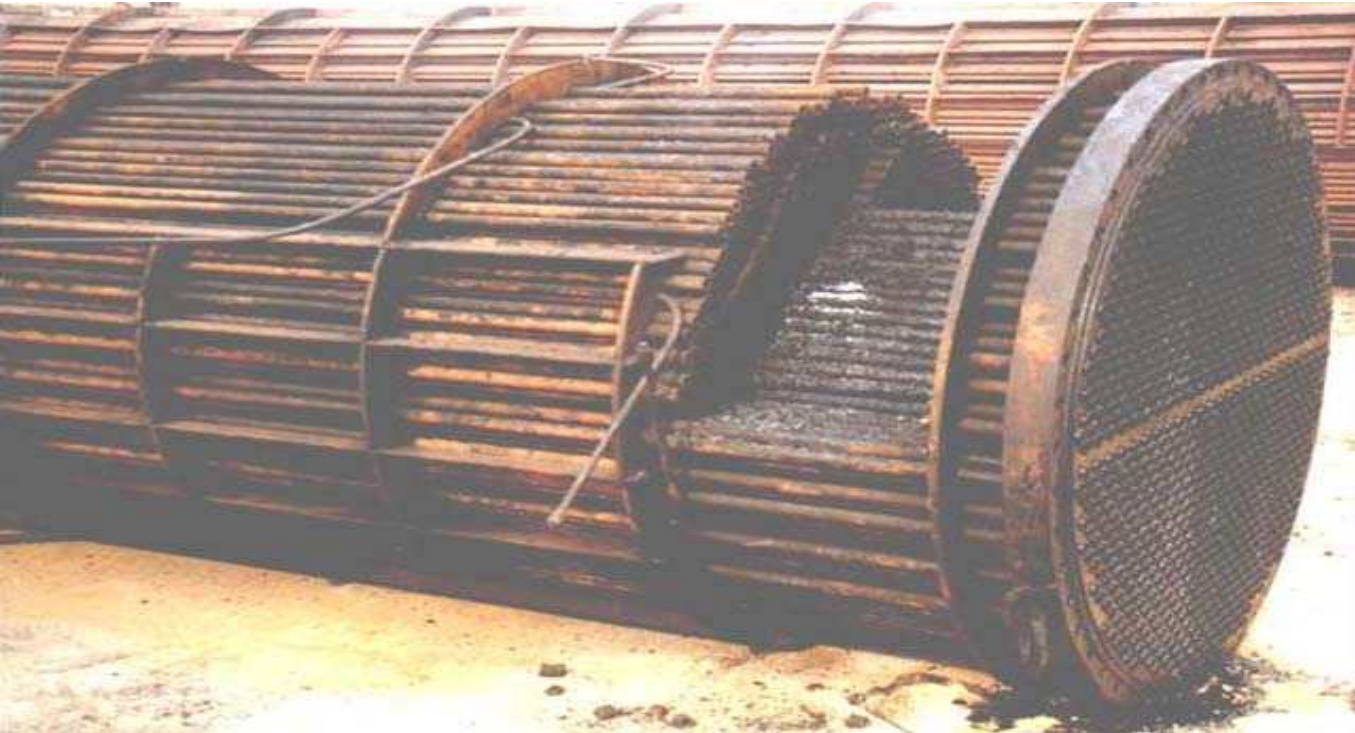

UPGRADING

KASERA offers valuable expertise to operators who are considering an upgrade. This can often be the solution when process demands have outstripped the original specification and the space or funds are not available for a new installation.

Our thermal and mechanical assessment will establish the best and most cost-effective upgrade within the limitations of your budget – our vast experience with fans, drives and other aspects of shell & tube heat exchanger technology can make this a surprisingly successful option.



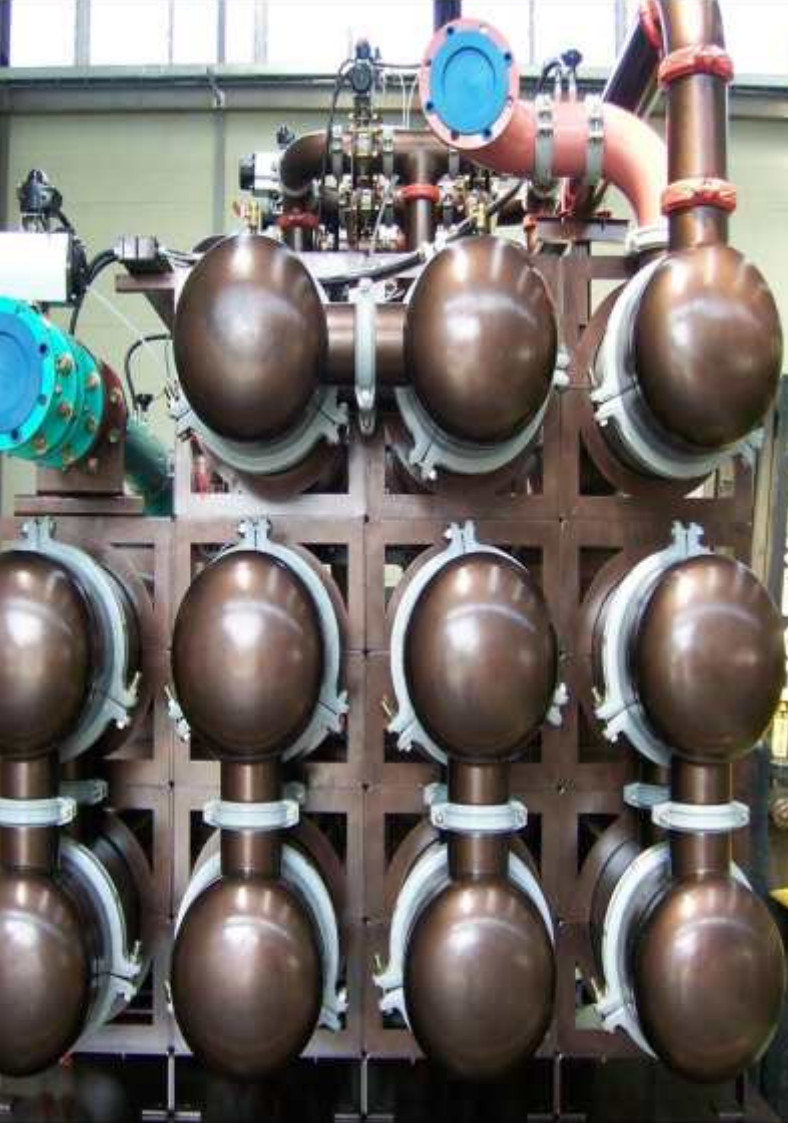

COOLING SYSTEMS

KASERA has a wealth of experience in designing and manufacturing shell & tube heat exchanger for a multitude of cooling applications. Our extensive experience includes, but is not limited to, Petrochemical industry, In Boiler, chemical industry, Gas Turbines for Power Generation, Heat Transfe and many more.

Our shell & tube heat exchanger are designed to meet the most onerous worldwide environments on sites from the Arctic to the Equator. Design and construction incorporate materials that ensure long and trouble free service with a minimum of maintenance. The heat transfer surfaces are selected from ARG' extensive range of fin and tube, finned tube systems and are optimised to suit the application in the most cost effective manner.

We employ a team of thermal engineers with extensive experience in solving the kind of problems likely to arise in this area of operations.

Quality Control

We have achieved full qualification to ISO 9001: 2000 in all stages of design and manufacture.

Rigorous Testing

We ensure all tube bundles are subject to through hydraulic tests appropriate to the cooling medium employed. We also have individual test rigs for transformer oil, turbine lubricating oil and water. These rigs incorporate flushing, filtration, flow and pressure loss measurement.

Every fan supplied as an integral part of our equipment is tested to ensure there are no inherent vibration problems, and that it complies with the appropriate specifications. In addition, noise levels can be measured if required.

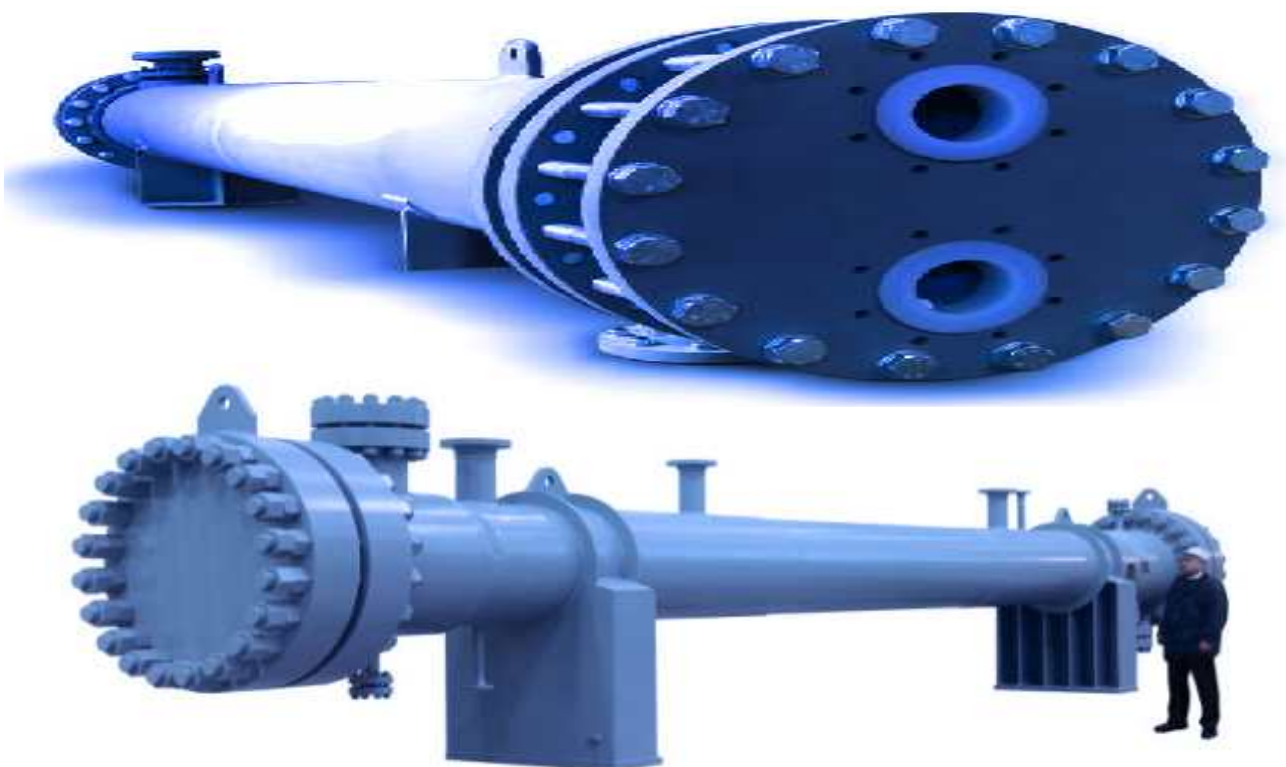

SERVICE

- ? **Chemical Cleaning**
- ? **Mechanical Brush Cleaning (Straight Thru design)**
- ? **Steam Pressure Washing**
- ? **Individual Tube Pressure Testing**
- ? **Onsite Cleaning Available**
- ? **Can repair or provide new Radiators**



Standard turnaround time 3 days or less! Contact us at +91-9680808888

KASERA also has door to door service facilities across India.

KASERA's Goal is to be customer's one stop Center for all Heat Exchanger needs offering complete service on all types of heat exchangers, (Shell and Tube, Plate & Frame, Fin tube heat exchanger). KASERA also offers a complete range of replacement plates and tubes for all Type of Heat Exchangers.

Your order is custom-designed by our team of professional engineers. Using advanced computer applications, we provide detailed drawings and supporting data sheets that will exactly, and economically, fit your application. In addition, a comprehensive quality control manual accompanies every shipment.

We offer you these services:

Retubing, From a single tube up to a complete tube bundle rebuild & Component replacement.

Re-rolling. Very often, tube-to-tube sheet joint leaks can be eliminated by re-rolling the tubes.

Tube-to-tube sheet joint welding. We perform strength and seal welding of tube ends.

Compliance with ASME code, Section VIII, Division 1 and TEMA requirements.

Component repair, leaks in top & bottom can be repaired by weld repair.

Hydro testing of heat exchanger.







ADDRESS:

KASERA HEAT TRANSFER PVT. LTD.
Shree Nath Tower, Near UIT, Ajmer Road,
Bhilwara, Rajasthan 311001 INDIA

TELEPHONE

Phone: +91 1482 238887
Fax: +91 1482 237887

Email ID :

For product information or assistance :
info@kaserahattransfer.com / export@kaserahattransfer.com

For after sale, service customer support or assistance:
service@kaserahattransfer.com

Live Customer Care Center +91 9680808888
Monday to Saturday 10.00am to 6:00pm (Indian Time)

Also use our telephone support center to contact a service representative during regular business hours.
Sunday is holiday please leave a message. A customer representative will contact you within 1 hour of your call in working days.